

# Angles at a Point **Answers**

I can calculate angles at a point.

Calculate and label the size of all the angles where each pair of lines intersect.

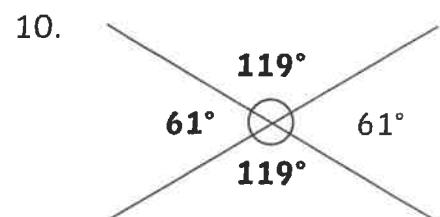
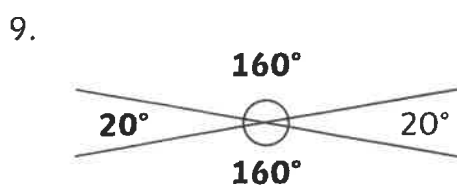
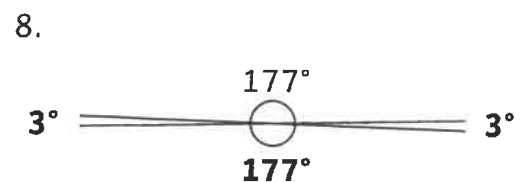
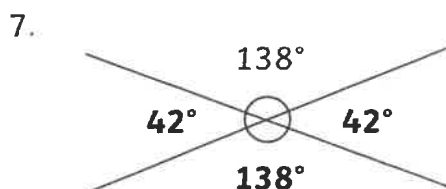
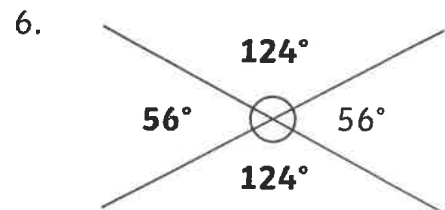
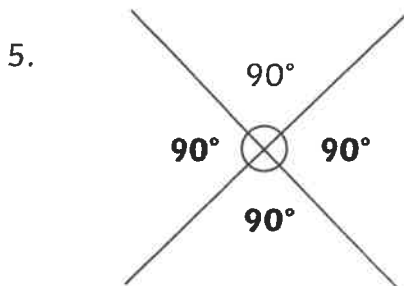
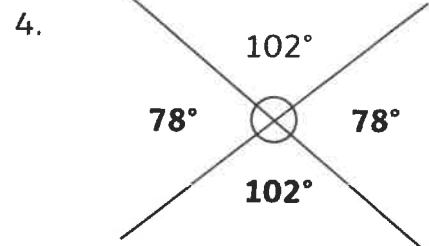
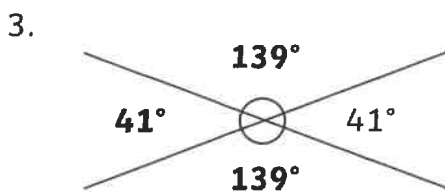
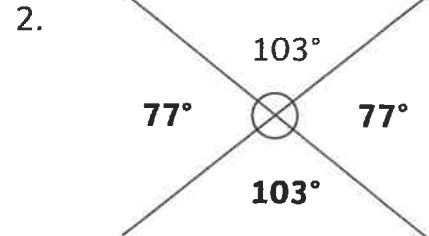
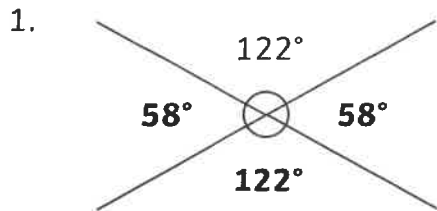

Complete the following sentences to explain how to calculate the angles where 2 lines intersect.

1. When two lines intersect the total of two adjacent angles is **180°**.
2. If one angle is known, the other can be found by **subtracting the known angle from 180°**.
3. When two lines intersect the total of all the angles **360°**.
4. The angles opposite the point are **equal**.

Here are 4 pairs of lines. Estimate the size of each angle, using what you know about angles at a point.

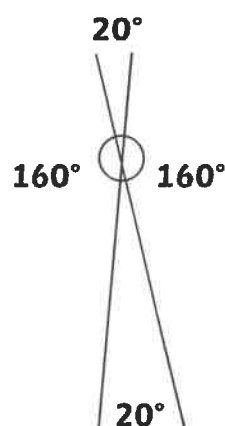
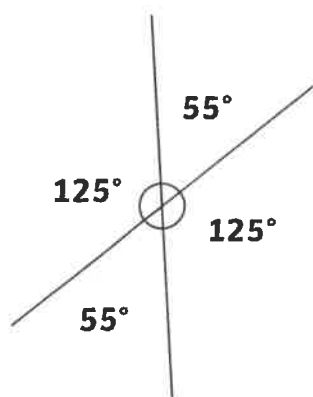
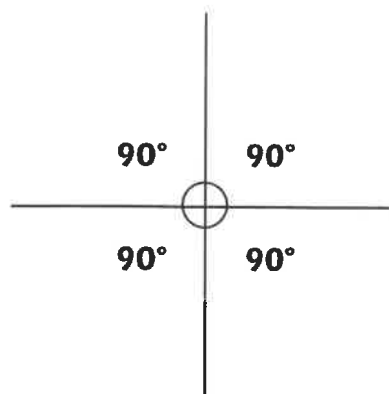
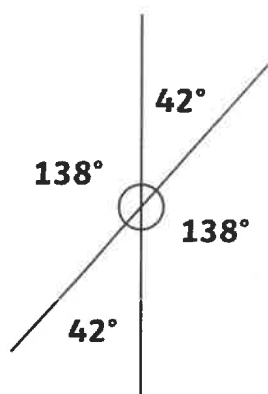

# Angles at a Point Answers

I can calculate angles at a point.

Calculate and label the size of all the angles where each pair of lines intersect.

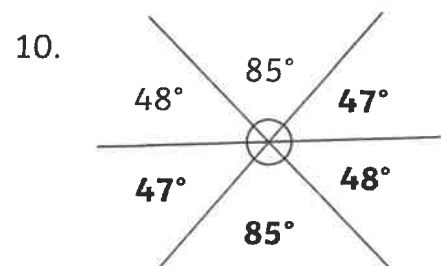
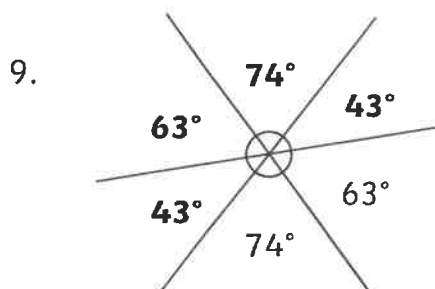
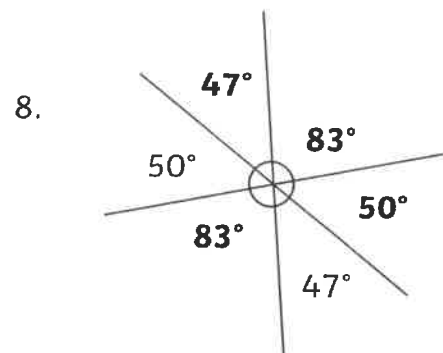
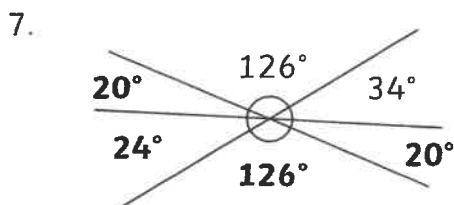
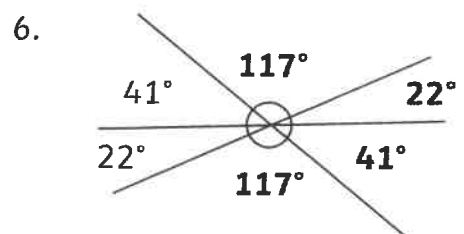
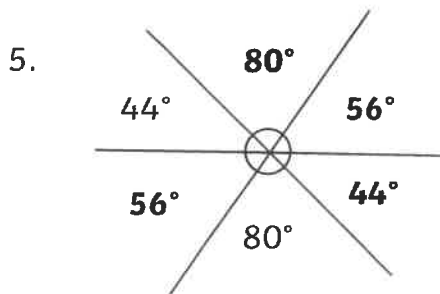
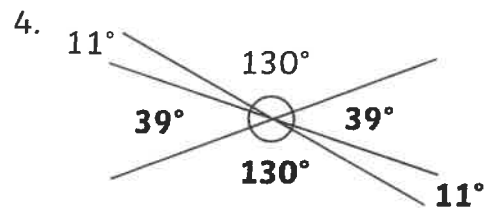
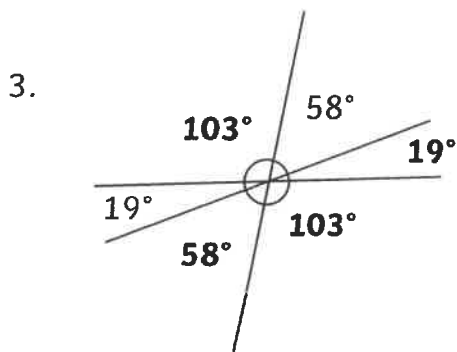
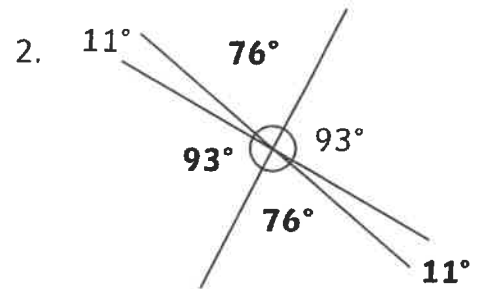
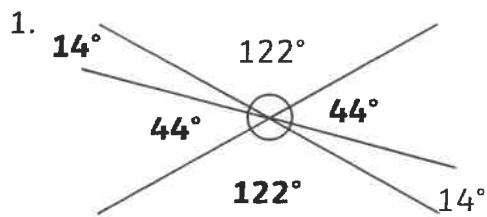

Write an explanation of how to find the unknown angles where 3 lines intersect and 2 angles that are not opposite are known.

**When 3 lines intersect at a point there are 6 angles. Opposite angles are equal so there will usually be 3 different angles. It is possible for 2 pairs (4 angles) to be equal, or all to be equal. 3 adjacent angles add up to  $180^\circ$  and all the angles add up to  $360^\circ$ . Where 2 angles are given, the other angle is the difference between the total of the known angles and  $180^\circ$ . If the 2 given angles are opposite, and therefore equal, the other angles cannot be calculated.**

Draw 2 sets of 3 lines intersecting at a point and estimate the size of each angle, using what you know about angles at a point.

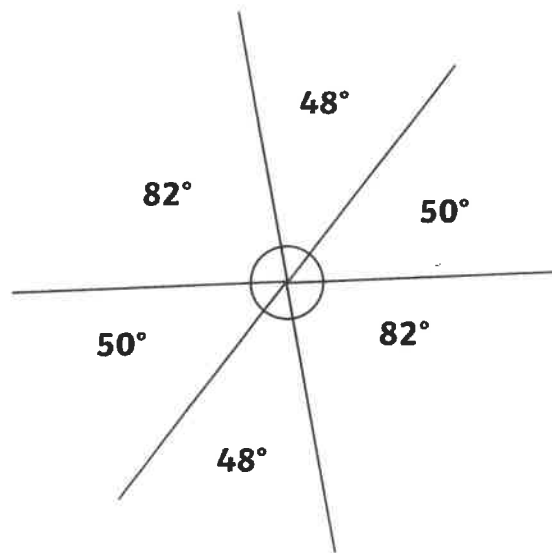

# Angles at a Point **Answers**

I can calculate angles at a point.

Here are 6 lines. There are 4 points where 3 lines intersect and one point where 2 lines intersect. Using the five given angles, calculate and label the size of all the other angles in the diagram.

